

MFJ 269 Antenna Analyzer  
- HF VHF **Main** -

Flow Chart Created by:  
Jim Jaworowicz  
AA8JR, Oct. 2002  
aa8jr@juno.com

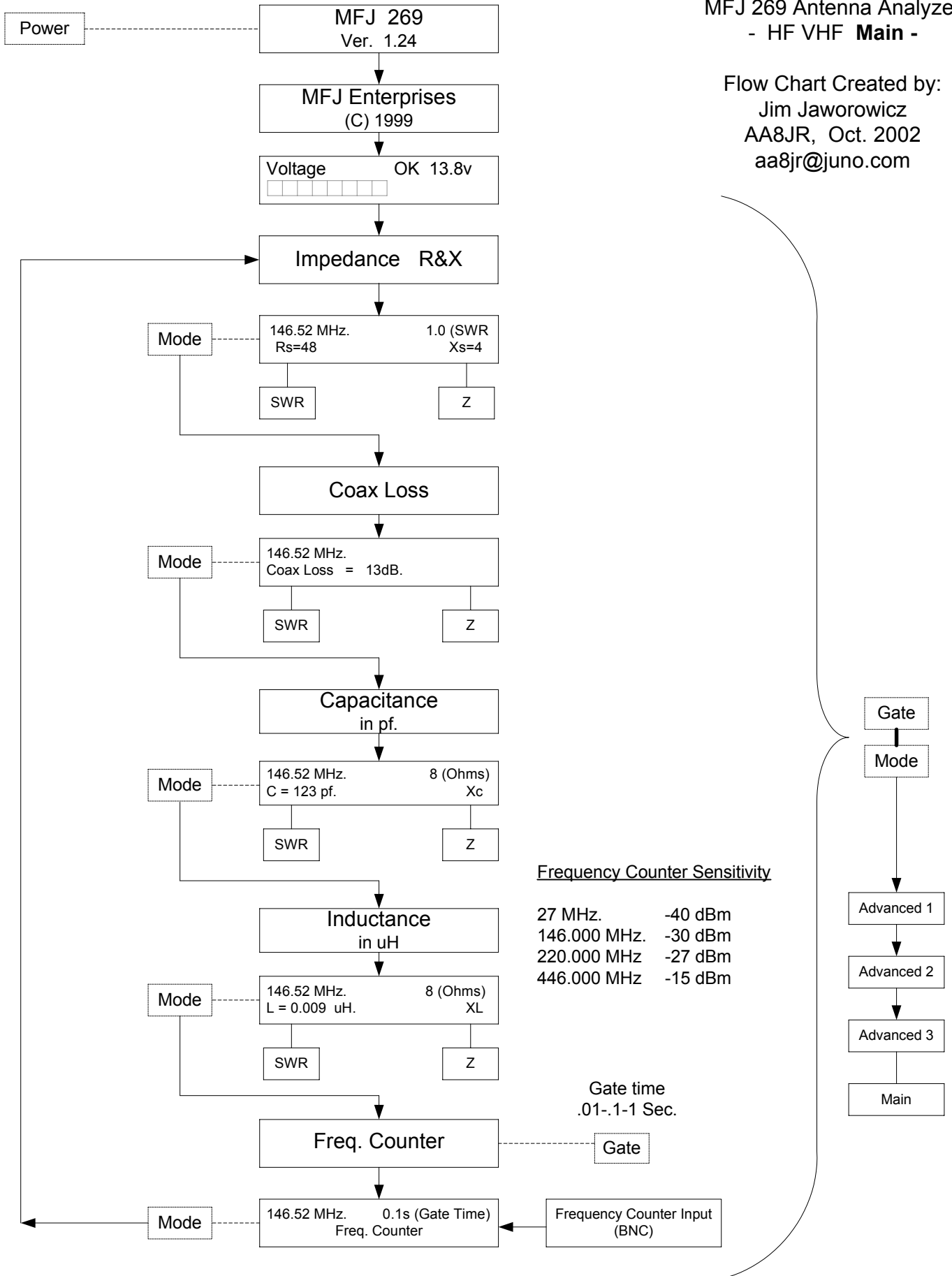

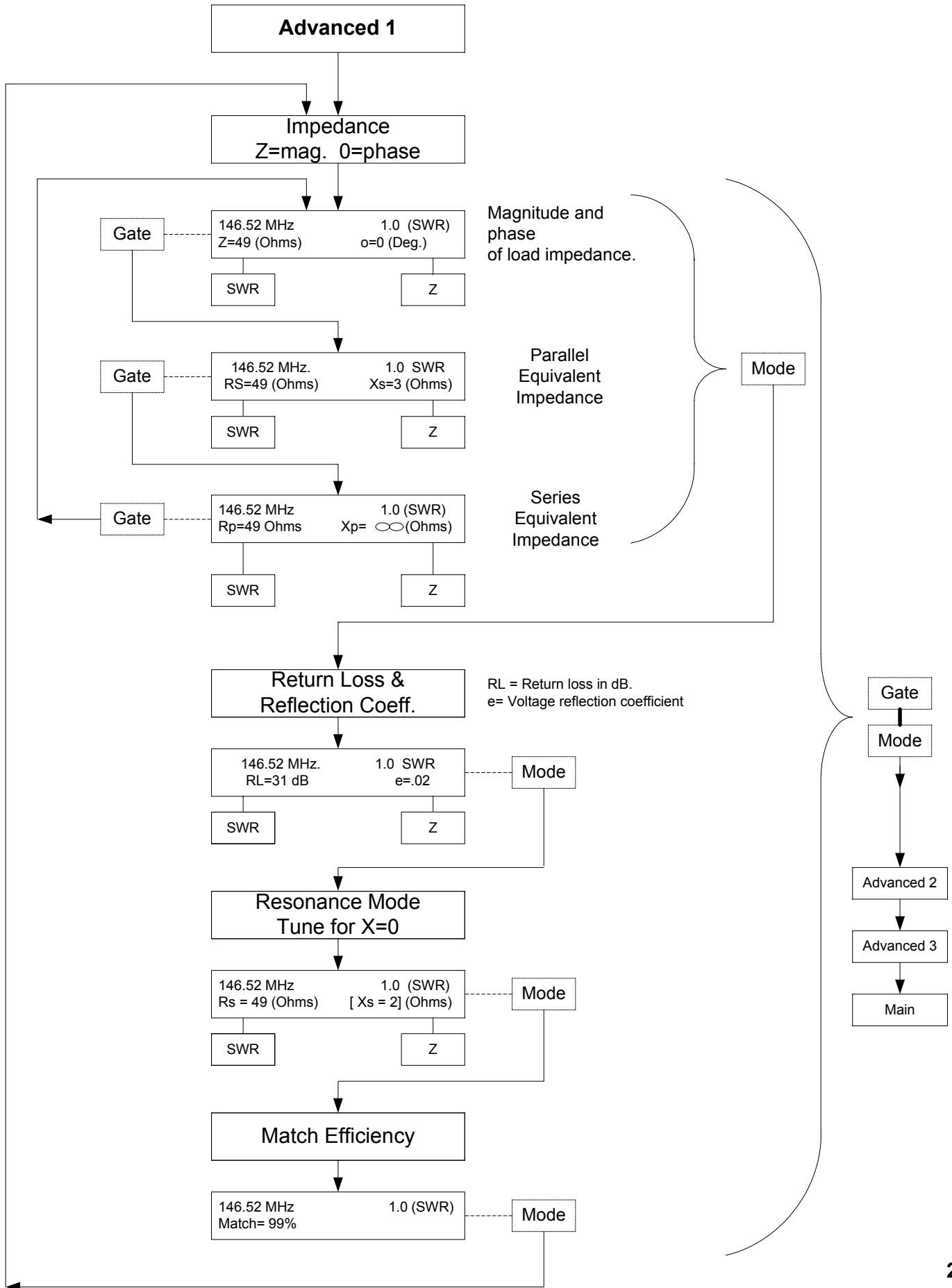

# Advanced 2

Gate increments VF  
Mode decrements VF

# HF - VHF - Advanced 2

Press both buttons to enter the selected VF.

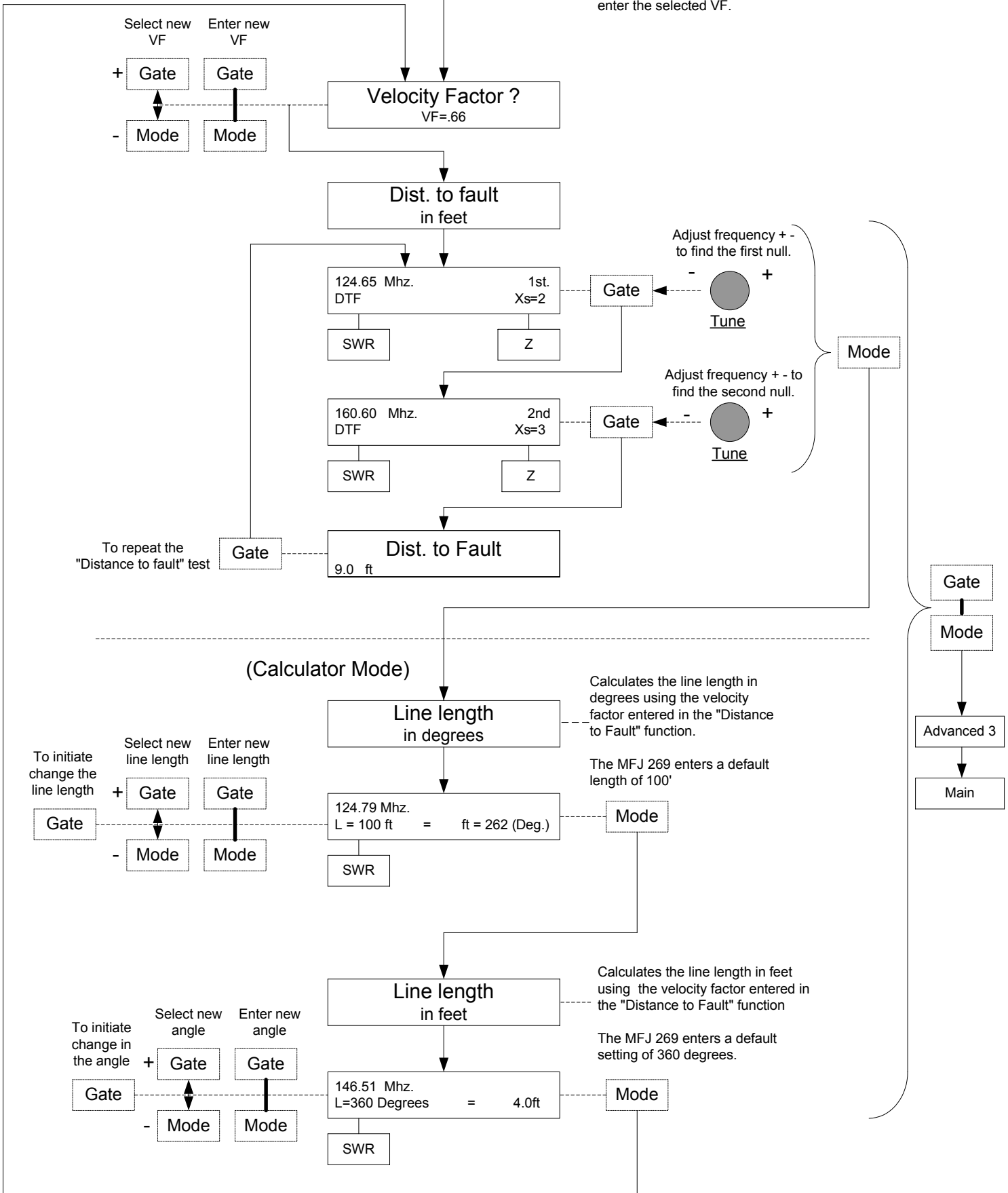

In this mode the output impedance of the MFJ-269 can be altered, allowing measurements to be made on cables and networks with characteristic impedance's other than 50 ohms.

